

Total solder points: 94

Difficulty level: beginner 1 2 3 4 5 advanced

CAR HEADLIGHT ALARM

K3505

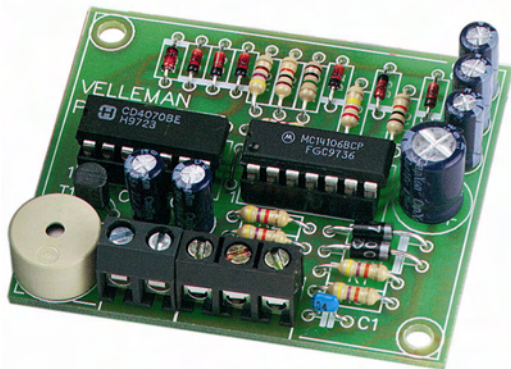

No more dead batteries due to
headlights that were left on.



VELLEMAN NV
Legen Heirweg 33
9890 Gavere
Belgium Europe
www.velleman.be
www.velleman-kit.com

Features:

- ☑ Continuously repeated alarm tone for lights ON (may be disabled)
- ☑ Repeated alarm tone for lights OUT
- ☑ Only 3 wires are required for hook-up

Specifications:

- Supply voltage: 12V battery
- PCB dimensions: 48 x 57mm (1.9" x 2.2")
- Recommended housing: WCAH2855

1. Assembly (Skipping this can lead to troubles !)

Ok, so we have your attention. These hints will help you to make this project successful. Read them carefully.

1.1 Make sure you have the right tools:

- A good quality soldering iron (25-40W) with a small tip.
- Wipe it often on a wet sponge or cloth, to keep it clean; then apply solder to the tip, to give it a wet look. This is called 'thinning' and will protect the tip, and enables you to make good connections. When solder rolls off the tip, it needs cleaning.
- Thin raisin-core solder. Do not use any flux or grease.
- A diagonal cutter to trim excess wires. To avoid injury when cutting excess leads, hold the lead so they cannot fly towards the eyes.
- Needle nose pliers, for bending leads, or to hold components in place.
- Small blade and Phillips screwdrivers. A basic range is fine.

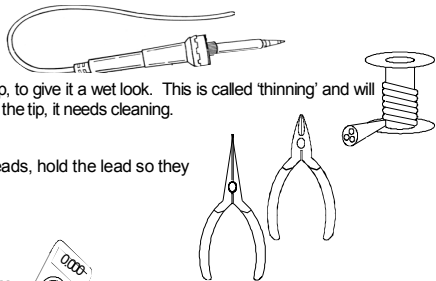

For some projects, a basic multi-meter is required, or might be handy

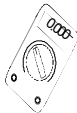

1.2 Assembly Hints :

- ⇒ Make sure the skill level matches your experience, to avoid disappointments.
 - ⇒ Follow the instructions carefully. Read and understand the entire step before you perform each operation.
 - ⇒ Perform the assembly in the correct order as stated in this manual
 - ⇒ Position all parts on the PCB (Printed Circuit Board) as shown on the drawings.
 - ⇒ Values on the circuit diagram are subject to changes.
 - ⇒ Values in this assembly guide are correct*
 - ⇒ Use the check-boxes to mark your progress.
 - ⇒ Please read the included information on safety and customer service
- * Typographical inaccuracies excluded. Always look for possible last minute manual updates, indicated as 'NOTE' on a separate leaflet.

1.3 Soldering Hints :

1- Mount the component against the PCB surface and carefully solder the leads

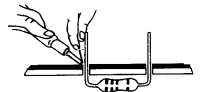

2- Make sure the solder joints are cone-shaped and shiny

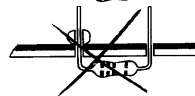
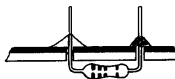

3- Trim excess leads as close as possible to the solder joint

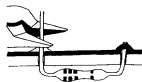

REMOVE THEM FROM THE TAPE ONE AT A TIME !

DO NOT BLINDLY FOLLOW THE ORDER OF THE COMPONENTS ON THE TAPE. ALWAYS CHECK THEIR VALUE ON THE PARTS LIST!

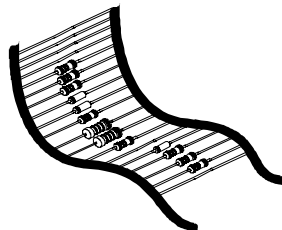

1. Jumper

- Between IC1 & IC2

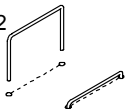
**2. Diodes. Watch the polarity !**

- D1 : 1N4148
 D2 : 1N4148
 D3 : 1N4148
 D4 : 1N4148
 D5 : 1N4148
 D6 : 1N4148
 D7 : 1N4148
 D8 : 1N4007
 D9 : 1N4007

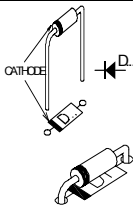
**3. Zener diode. Watch the polarity !**

- ZD1 : 2V4

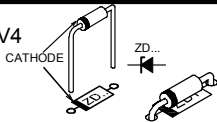
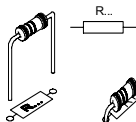
**4. Resistors**

- R1 : 47K (4 - 7 - 3 - B)
 R2 : 47K (4 - 7 - 3 - B)
 R3 : 47K (4 - 7 - 3 - B)
 R4 : 47K (4 - 7 - 3 - B)
 R5 : 220K (2 - 2 - 4 - B)
 R6 : 470 (4 - 7 - 1 - B)
 R7 : 470 (4 - 7 - 1 - B)
 R8 : 10K (1 - 0 - 3 - B)
 R9 : 10K (1 - 0 - 3 - B)
 R10 : 1M (1 - 0 - 5 - B)

5. IC sockets, Watch the position of the notch !

- IC1 : 14p
 IC2 : 14p

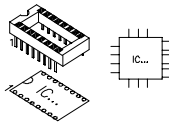
**6. Capacitor.**

- C1 : 100nF (104)

**7. Transistor.**

- T1 : BC547B

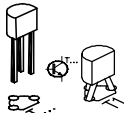
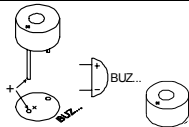
**8. Buzzer**

- Buz1

Remove the safety sticker from the buzzer, if any.

9. Electrolytic Capacitors. Watch the polarity !

- C2 : 22 μ F
- C3 : 22 μ F
- C4 : 22 μ F
- C5 : 22 μ F
- C6 : 22 μ F
- C7 : 470 μ F

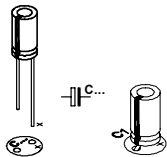

10. Screw connectors

- J1 : 2P
- J2 : 3P

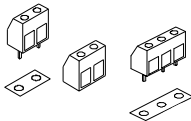

11. IC's. Check the position of the notch!

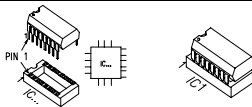

- IC1 : CD40106 or eq.
- IC2 : CD4070 or eq.

12. Use and connection

Mount the circuit underneath the dash board and make the following connections: (see Fig. 1.0)

- Connect the GND connection with the chassis or the battery (-) pole.
- Connect the L connection with the connection carrying voltage when the lights are turned on.
- Connect the C connection with the connection carrying voltage when the contact is switched ON.

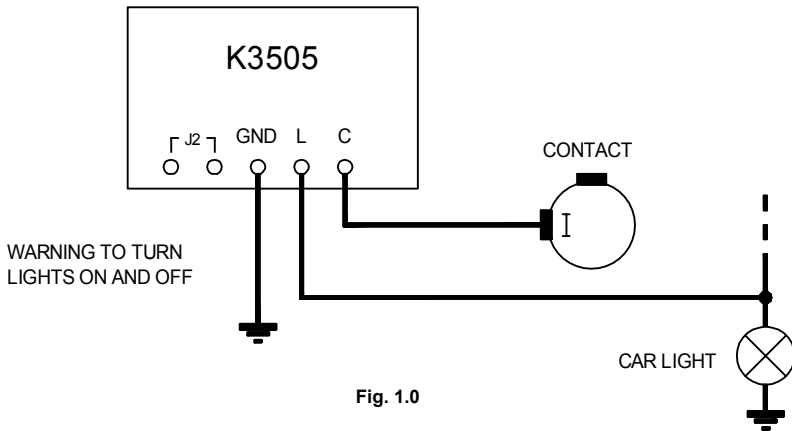

Fig. 1.0

If the alarm should only operate when the driver forgets to turn off the lights, a jumper should be inserted between the J2 connections.

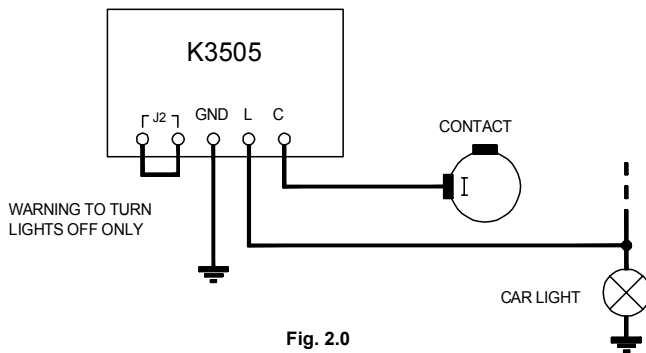
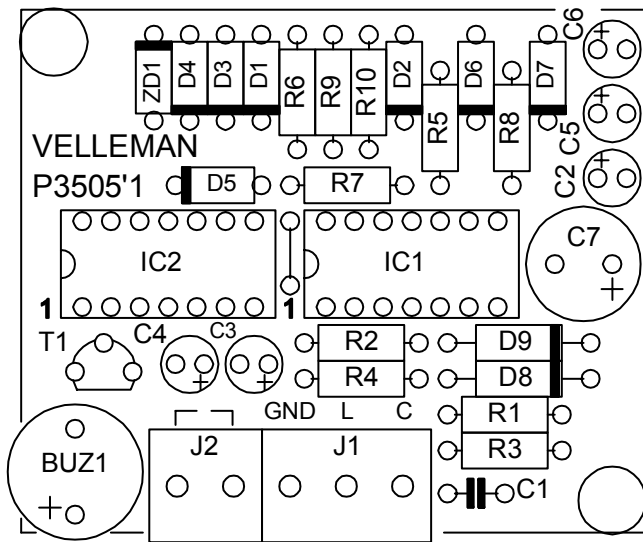
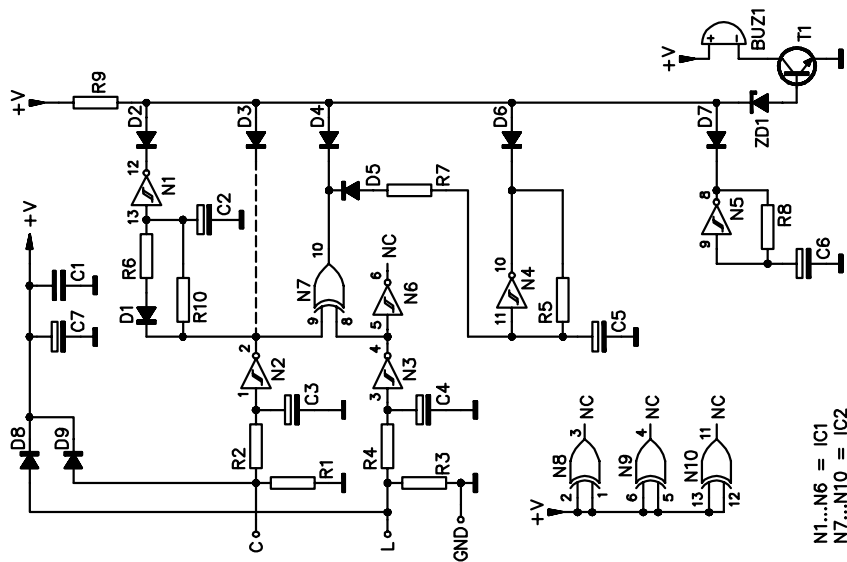

Fig. 2.0

13. PCB layout.



14. Diagram



VELBUS
Velleman Home Automation System

**All appliances get intelligent, how about your home?
see our website : www.velbus.be**

Modifications and typographical errors reserved
 © Velleman Components nv.
 H3505IP - 2004 - ED1

VELLEMAN NV
Legen Heirweg 33, 9890 Gavere
Belgium - Europe

